



DATE: _____ COMPANY: _____

CONTACT: _____ PHONE No.: _____ FAX No.: _____

APPLICATION ENGINEERING INFORMATION FOR AC PROTECTION:

To enable us to assist you in choosing the correct transient voltage surge protection device and design, please supply us with the following information regarding your electrical service.

Amperage Rating and Service Voltage
(E.g., 120, 240/120, 208/120.208, 240, 415/240, 480/277) _____

Single or 3-Phase Configuration and Wiring
(2, 3, or 4 Wire & Ground) _____

Wire feet distance from main service panel to sub-panel _____

Maximum Voltage:
(We need to know this to assure that the suppressor will only turn on during transient events, not during normal operation) _____

Voltage Regulation:
Is there a voltage regulator installed? _____
If yes, where in the system is the voltage regulator installed? _____
If yes, will the surge suppression be installed on the equipment side or the utility side of the voltage regulator? _____

If there is a transformer before the sub-panel:

KVA rating of the transformer, voltage configuration in and out _____

Wire feet between the transformer and sub-panel _____

Voltage tolerances of equipment to be protected _____

Any comments or specific requirements (relating to protection, design constraints (size, hardwire, plug w/receptacle) or budgetary constraints. List equipment to be protected:

FOR T1 OR TELCO PROTECTION:

Peak Signal Voltage (Include any D.C. Bias) _____

Connection made via RJ plug or hardwire?
(All units utilize RJ45 plugs) _____

Signal Frequency?
(All units pass 1.544 Mb/s, the T-1 Standard) _____

SITE INFORMATION FORM (ONE REQUIRED FOR EACH SITE)
 SPECIFY LENGTHS AND EQUIPMENT TYPE WHERE (?) APPEARS
 IF THIS SKETCH IS NOT SUFFICIENT, PLEASE USE REVERSE SIDE
 OR ANOTHER SHEET OF PAPER,

IF THERE ARE OTHER TRANSFORMERS/DISTRIBUTION EQUIPMENT TRANSFORMER?
 PLEASE PROVIDE SKETCH OR CONTACT A.C./DATA SYSTEMS

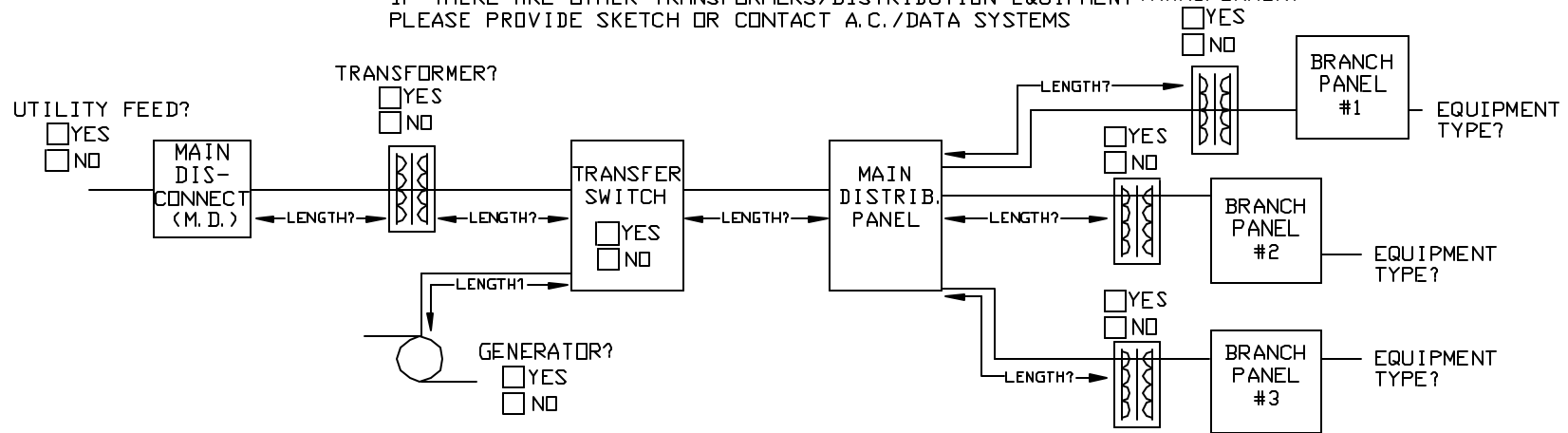

	EXAMPLE	MAIN DISCONNECT	TRANSFER SWITCH	MAIN DISTRIB. PANEL	BRANCH PANEL #1	BRANCH PANEL #2	BRANCH PANEL #3	
VOLTAGE	380/220							
CURRENT	500							
# PHASES	3							
# HOT WIRES	3							
NEUTRAL (YES OR NO)	YES							
LENGTH (FT.) FROM M. D.	5							

EQUIPMENT TYPE EXAMPLES:
 RADIOS
 AIR CONDITIONERS
 COMPUTERS
 RECTIFIERS

LENGTH FROM GENERATOR TO TRANSFER SWITCH (IF USED) _____